

2023 USDF INTRODUCTORY LEVEL – TEST C

WALK—TROT—CANTER

REQUIREMENTS:
 Free walk
 Medium walk
 Working trot rising
 Working canter
 20 meter circle
 Halt through walk

PURPOSE: To introduce the rider and/or horse to the sport of dressage, confirming that they are beginning to develop an understanding of correct dressage basics. The horse should be ridden freely forward in a steady tempo and clear rhythm, accepting contact with the bit. An understanding of test accuracy and geometry should be demonstrated.

NO.

READER PLEASE NOTE: Anything in parentheses should not be read.

TEST		DIRECTIVE IDEAS	POINTS	COEF	TOTAL	REMARKS
1.	A X	Enter working trot rising. Halt through medium walk. Salute - Proceed working trot rising	Regularity; quality of trot; willing, calm transitions; straightness; attentiveness; immobility (min. 3 seconds)			
2.	C	Track right, working trot rising	Regularity; bend and balance in turn and corner			
3.	B	Circle right 20 meters, working trot rising	Regularity; shape and size of circle; bend; balance			
4.	A Before A	Circle right 20 meters developing working canter in first quarter of the circle, right lead Working trot rising	Regularity of gaits; shape and size of circle; bend; balance			
5.		(Transition in & out of canter)	Willing and calm transitions			
6.	K-X-M	Change rein, working trot rising	Regularity of trot; straightness; bend and balance in corners			
7.	E	Circle left 20 meters, working trot rising	Regularity; shape and size of circle; bend; balance			
8.	A Before A	Circle left 20 meters developing working canter in first quarter of the circle, left lead Working trot rising	Regularity and quality of gaits; shape and size of circle; bend; balance			
9.		(Transition in & out of canter)	Willing and calm transitions			
10.	Between F & B	Medium walk	Willing, calm transition; regularity, quality, overtrack			
11.	B-H H	Free walk Medium walk	Regularity and quality of walks; reach and ground cover with overtrack; allowing complete freedom to stretch the neck forward and downward; straightness; Willing, calm transitions			
12.	Between C & M	Working trot rising to A	Willing, calm transition; regularity of trot; bend and balance in corner; straightness			
13.	A X	Down centerline Halt through medium walk Salute	Bend and balance in turn; regularity of trot; willing, calm transition; straightness; attentiveness; immobility (min. 3 seconds)			

Leave arena in free walk. Exit at A.

COLLECTIVE MARKS:

Gaits (freedom and regularity).			
Impulsion (desire to move forward with suppleness of the back and steady tempo).			
Submission (acceptance of steady contact, attention, and confidence).		2	
Rider's position (keeping in balance with horse).			
Rider's effectiveness of aids (correct bend and preparation of transitions).			
Geometry and accuracy (correct size and shape of circles and turns).			

200

FURTHER REMARKS:

SUBTOTAL _____
ERRORS (-) _____
TOTAL POINTS _____

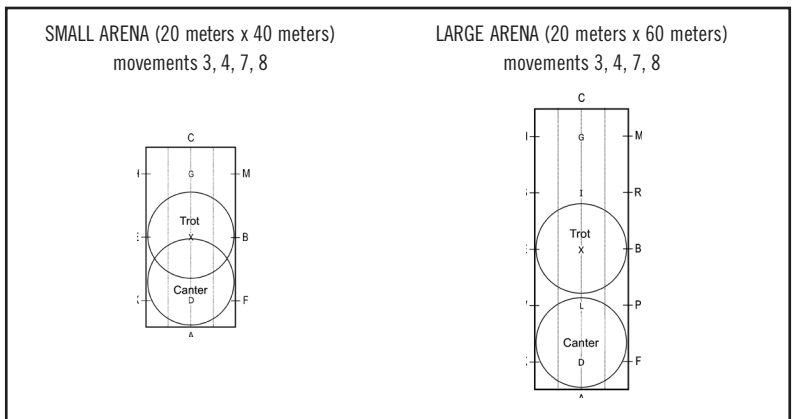

To be deducted
 Errors of the course and omissions
 are penalized 1st Time = 2 points
 2nd Time = 4 points
 3rd Time = Elimination

©2022 United State Dressage Federation. All Rights reserved. Reproduction without permission is prohibited by law. USDF is not responsible for any errors or omissions in the publication nor for the use of its copyrighted materials in any unauthorized manner.

UNITED STATES DRESSAGE FEDERATION™
2023
INTRODUCTORY LEVEL – TEST C
WALK—TROT—CANTER

USDF
 INTRODUCTORY
 LEVEL TEST
C

This unique series of tests provides an opportunity for the horse and/or rider new to dressage to demonstrate elementary skills. The tests have been designed to encourage correct performance and to prepare the horse for the transition to the USEF tests.

SUGGESTED SCHEDULING TIME

6:00 Standard Arena
 5:00 Small Arena
 (Possibly longer for schooling shows)

INSTRUCTION:

- All trot work to be ridden rising.
- Transitions from trot to canter and canter to trot may be performed through sitting trot with the objective of performing a smooth transition.
- Turns from centerline to long side and long side to centerline should be ridden as a half circle, touching the track at a point midway between the centerline and the corner, and vice versa.

COMMENT:

Horses should be ridden on a light but steady contact, with the exception of the free walk in which the horse is allowed complete freedom to stretch neck forward and downward.

MAXIMUM POSSIBLE POINTS: 200

FINAL SCORE

Points _____ Percent _____

Name of Judge/Position _____

Signature of Judge _____

Score Sheet effective date: December 1, 2022 – November 30, 2026



United States Dressage Federation™
 4051 Iron Works Parkway • Lexington, KY 40511
 Phone (859) 971-2277 • Fax (859) 971-7722
 usdresage@usdf.org • www.usdf.org